

Preferred Pack[®]

CARTON SEALERS - MODEL CT-50*

The New Industry Standard for Quality and Reliability

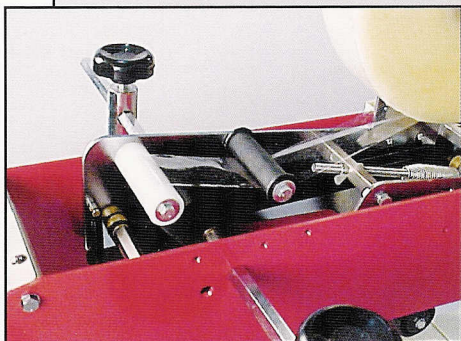
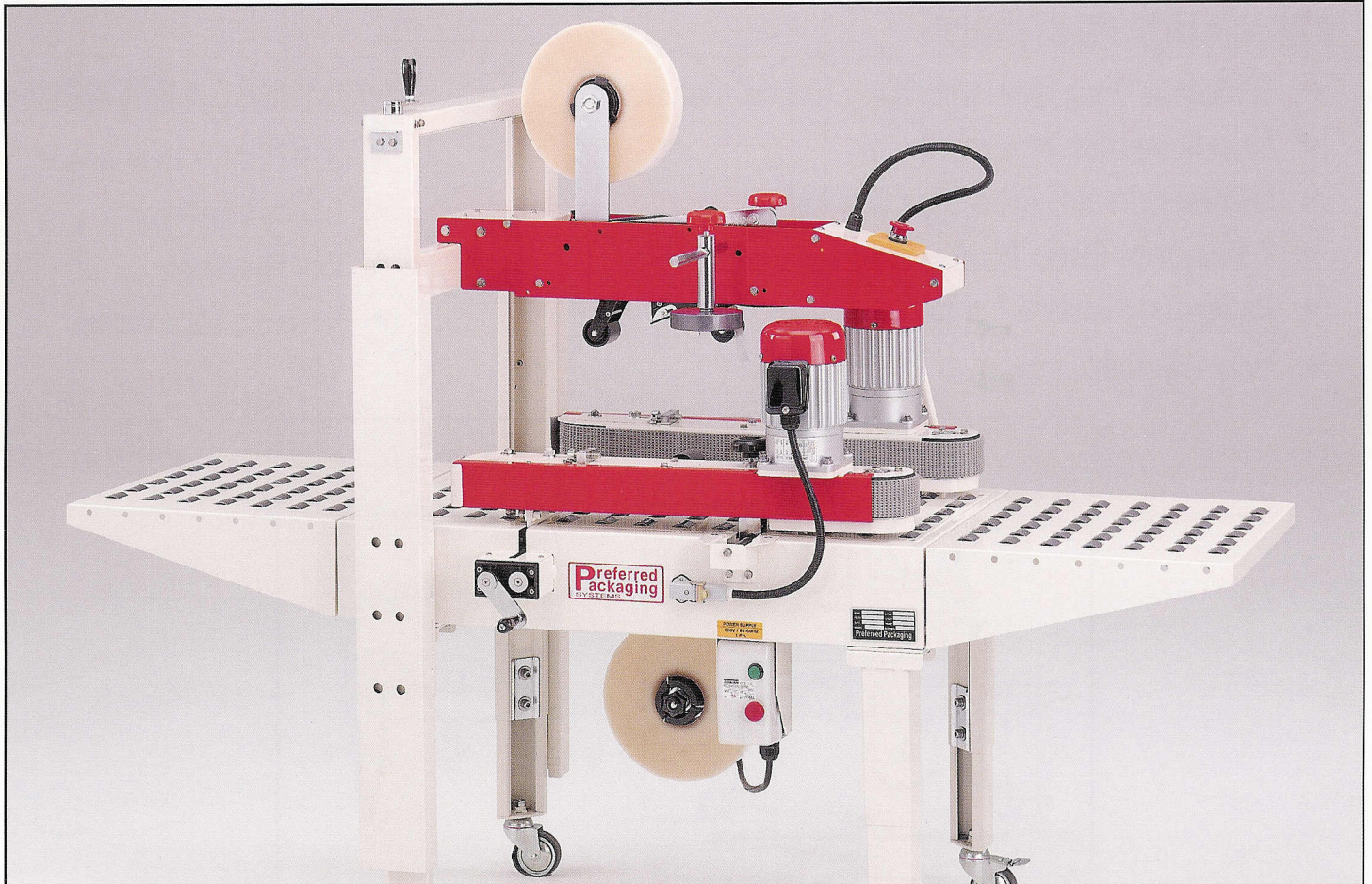

Patented "Easy Thread" Tape Design With Adjustable Box Side Guides.

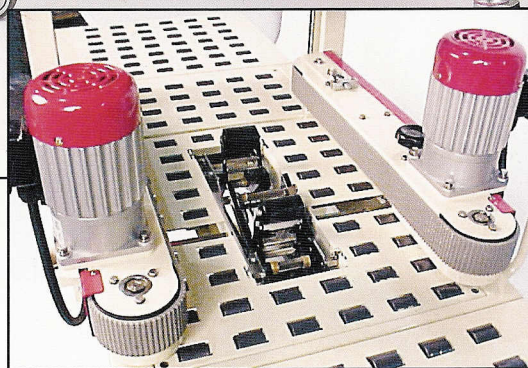

Heavy Duty Dual Side Drive Belts For Positive Grip Pressure.

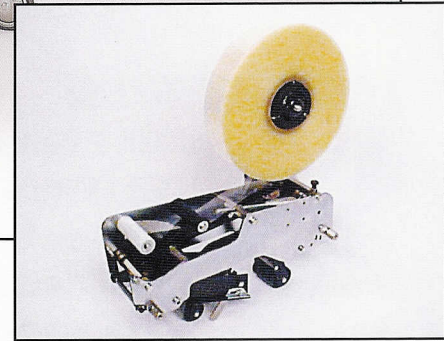

This American Designed Tape Head Features A Patented "Floating Crowned Roller" To Keep Bottom Tape Standing Tall.

Semi-Automatic Uniform Carton Sealer with Easy Manual Carton Size Adjustment. Side Drive Belt Design. Featuring Our New Patented Tape Head with "Easy Thread Design." Machine Comes Complete with Adjustable Height Legs and Locking Casters.

* Shown with Optional Infeed and Discharge Rollers

The operator simply folds the top flaps of the corrugated carton and feeds it into the machine. The CT-50 applies a single tape strip to both the top and bottom of the case simultaneously. This two belt drive design is a heavy duty versatile machine designed for dependable performance and easy operation. The CT-50 can be easily adjusted in only seconds to process a different size carton. Excellent for low profile, small, lightweight boxes.

STANDARD FEATURES:

- "Patented" Tape Head with "Easy Thread" Design
- Interchangeable Tape Heads
- Side Pressure Rollers to Close Box Top
- 2 Side Drive Belts - Positive Feed
- Heavy Duty Locking Casters
- Fully Adjustable Legs

OPTIONAL FEATURES:

- 3" (72mm) Tape Heads
- Infeed Conveyor
- Exit Conveyor
- Stainless Steel Frame

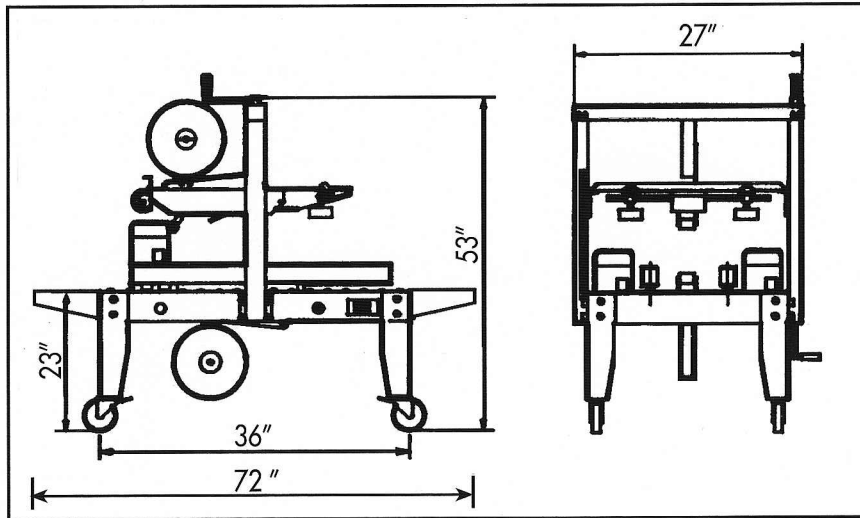

SPECIFICATIONS:

CARTON SIZE:	LENGTH: 6" min. to Infinite	ELECTRICAL: 110 Volt, 1 Phase, 10 Amp
	WIDTH: 4.5" min. to 18.5" max.	WEIGHT: 260 lbs. Shipping Weight: 310 lbs.
	HEIGHT: 4" min. to 19.5" max.	MAX BOX WEIGHT: 65lbs.
MACHINE SIZE:	36'L x 27"W x 53"H	TAPE HEAD SPECS: 2" (48mm) Wide - 1,000 yard or 1,500 yard rolls.
MACHINE SPEED:	75ft./min. up to 2500 cartons per hour. Production rate depends on carton size and operator dexterity	WARRANTY: 1 Year on all parts

AUTHORIZED DISTRIBUTOR