

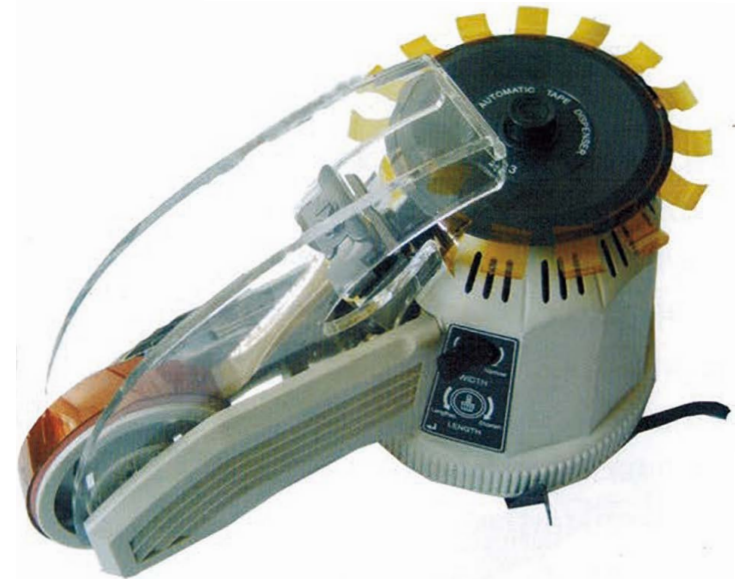

02 9452-3566

sales@getpacked.com.au

## Z-CUT 2 OPERATING INSTRUCTIONS



For your safety, please read this "operating Instruction" carefully before operating. And always keep this manual within reach.

## 目 录

Z-CUT2视图/ZCUT2 OVERVIEW.....	1
简介/INTRODUCTION.....	2
使用前说明/BEFORE USE.....	2
带盘安装/HOW TO SET THE BOBBIN.....	2
胶带安装/HOW TO SET THE TAPE.....	3
操作步骤/OPERATIONS.....	3
取胶带/HOW TO REMOVE TAPE FROM THE CAROUSEL.....	3
胶带调整/HOW TO ADJUST THE TAPE.....	4
刀片/THE BLADES.....	4
取出上刀片/ HOW TO REMOVE THE UPPER BLADE.....	4
取下框臂/HOW TO REMOVE THE ARM FRAME.....	4
取出下刀片/HOW TO REMOVE THE LOWER BLADE.....	4
安装刀片/PUTTING THE NEW BLADES ON.....	5
调整上刀片/HOW TO ADJUST THE UPPER BLADE.....	5
维护/MAINTENANCE.....	5
警告/WARRANTY.....	5
零件清单/PARTS LIST TAPE DISPENSER.....	6
性能参数/SPECIFICATIONS.....	7
零配件图/PARTS.....	7

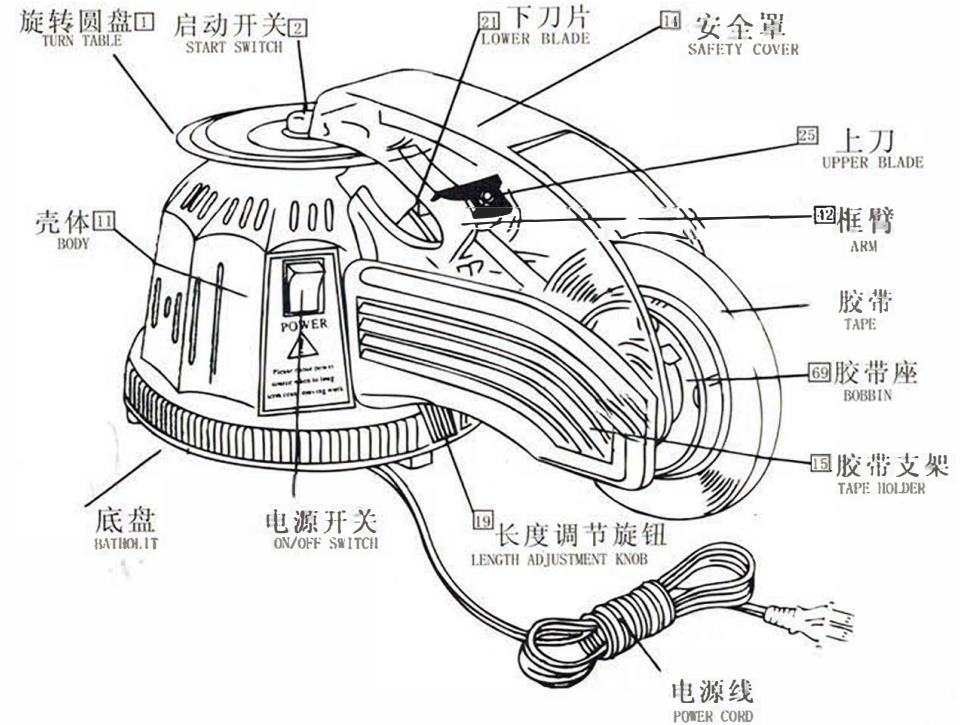
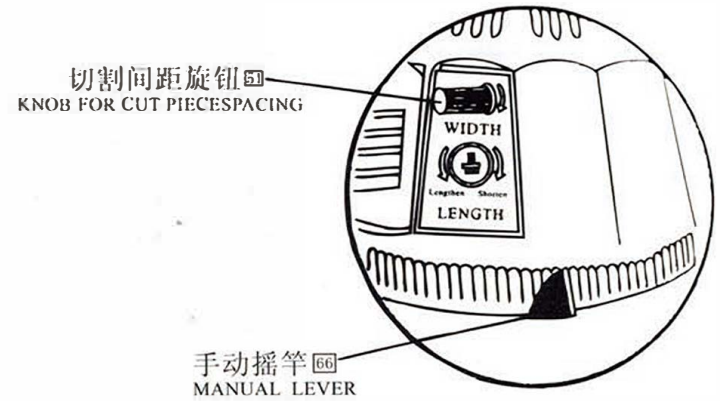

## 简介

感谢购买我们的自动胶带切割分配机。这种机器可以自动切割分配各种胶带。在使用之前，请仔细阅读说明书。

## 使用前说明

- 1、接通电源之前，请确认电源开关已关闭。
  - 2、安装胶带之前，请确认电源开关已关闭，再根据指示安装胶带。
  - 3、刀片特别锋利，机器工作时务必合上安全罩。安装胶带的时候，请小心，勿将手指放于刀片之间。
  - 4、旋转圆盘上有手印、油渍和污物时，胶带不易粘牢。如果旋转圆盘上有这些东西，请用一块清洁干布擦拭干净。
- 注意：当大量污物时，请用轻质汽油或酒精擦拭旋转圆盘（禁止用稀释剂擦拭）
- 5、放入胶带以胶测试机器，你只需测试两三次即可，多次测试会减短马达的使用寿命。
  - 6、这是一种商用机器，不适合家庭使用。请勿让儿童及不会使用接近机器。
  - 7、这种机器可供一人或多人同时使用，请尽量避免过度使用机器，给马达一点休息时间。

## 带盘安装

- 1、电源开关必须关闭。  
注：当不使用机器时，务必拔掉电源线。
- 2、选择合适的胶带盘。  
注：内径—25、32、78mm  
外径—最大至130mm
- 3、将胶带装在带盘上。  
注：检查带盘方向，把胶带按入到指定位置。
- 4、拉出约100mm长的胶带，将带盘放入支架。  
注：如果胶带跟带盘之间有间隙，可在带盘上绕一些胶带，使两者贴合。

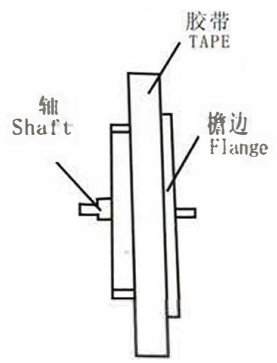
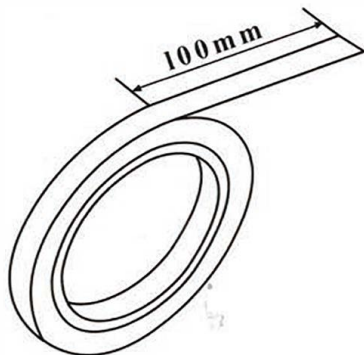

## INTRODUCTION

Thank you for our automatic tape dispenser. The ZCUT2 can automatically cut and dispense many types of tape. Before using, please read this instruction manual carefully.

## BEFORE USE

1. Make sure the ON/OFF switch is turned to the "off" position before you plug the ZCUT2 IN.
2. When you load the tape, make sure that the ON/OFF switch is "off".
3. The blades are very sharp. When the ZCUT2 is in operation, make sure the safety cover is down.
4. When there are finger marks, oils, and/or dirt on the carousel, the tape won't stick properly so use a dry cloth to clean the carousel.  
Note: For major cleaning, wipe the carousel off with Benzene or alcohol (Never clean it with thinner)
5. To avoid shortening the life of the motor, run the ZCUT2 without tape as little as possible.
6. This is an industrial tape dispenser. It is not for home use. Do not use around children.
7. The ZCUT2 can be used efficiently by one or two people. Allow the motor to rest from time to time.

## HOW TO SET THE BOBBIN

1. The ON/OFF switch must be "off". Note: When not in use, unplug the ZCUT2.
2. Choose the right bobbin 69 for the tape. Note: internal diameter—25.32 and 78mm, Outside diameter—Up to 130mm.
3. Put the tape on the bobbin.  
Note: Check the direction of the bobbin, and push the tape to the limit of the flange.
4. Pull out approximately 100mm of tape, put the bobbin on the tape holder. Note: If there is space between the tape core and bobbin, wrap a piece of 15 around the bobbin to make it fit.

## 胶带安装

- 1、关闭电源开关，打开安全罩，使用手动摇杆移动框臂。
- 2、调整刀片一直至刀片将要夹到旋转圆盘上。（参见插图）

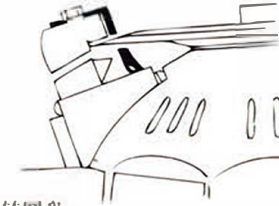

- 3、把框臂脱离旋转圆盘。
- 4、将胶带从刀片之间穿过并粘贴在旋转圆盘上。  
注：粘贴胶带时必须使它处于中间位置，并在旋转圆盘上粘牢。
- 5、如果不能正确安装胶带，重复1-4操作步骤。

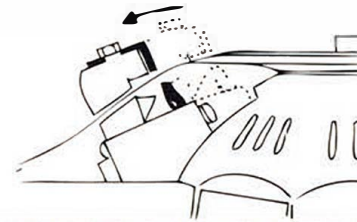

## HOW TO SET THE TAPE

1. The ON/OFF switch must be "off". Open the safety cover 14. Move the arm frame 42 using the manual lever 66.
2. Set the blades as if they were going to "bite" the carousel.
3. Bring the arm frame 42 away from the carousel.
4. Pull the tape through the blades and affix the tape carousel.  
Note: When you stick the tape to the carousel, be sure to pull the tape all the way through the middle of the carousel and affix firmly.
5. If you haven't set the tape correctly, repeating steps 1 through 4.

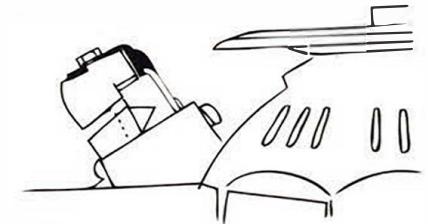

## 操作步骤

- 1、打开电源开关。
- 2、按下旋转圆盘上的启动开关。  
胶带切片被分配在绕圆盘一半左右的地方。
- 3、在切割胶带以前，通过切割两三片测试检查一下胶带的切割所需要长度的精确程度。  
注：一旦圆盘已满，在重新启动机器前务必取走圆盘上胶带切片。
- 4、如果想让胶带切片粘满圆盘，可以再按一下启动开关。
- 5、如果马达过热，自动调温器会自动停止机器。当这种情况发生时，务必让马达冷却之后再使用。
- 6、无论何时打开安全罩，机器就会自动停止。
- 7、总之必须保持使用中操作安全。

## 取下胶带

从胶带支架的左侧取下胶带，接着沿右侧向前取下胶带。

## OPERATIONS

1. The ON/OFF switch must be "on".
2. Press the start 2 on the carousel. The cut pieces of tape will be distributed about half way around the carousel.
3. Before you begin operation, test the process by cutting two or three pieces. Check the precision length of the cut.
4. To make the tape feed all the way around the carousel, press the start 2 switch again.  
Note: Once the carousel is full, be sure to remove the pieces of tape before you start the ZCUT2 again or else the will overlap.
5. If the motor overheats, the thermostat will automatically shut the ZCUT2 off. When that happens, let the motor cool before further use.
6. Whenever you open the safety cover 14 the ZCUT2 will stop automatically.

## HOW TO REMOVE TAPE FROM THE CAROUSEL

Begin taking the tape off from the left side of the tape holder 15, continue around clockwise.

## 胶带调整

你可以在机器开始前或停止的时候调整胶带长度和间距。

- 1、旋转长度调节旋钮到所需的切割长度。
- 2、旋转向距调节旋钮到所需的间距。



## HOW TO ADJUST THE TAPE

You can adjust the length and the cutpiece spacing whether the ZCUT2 is "off" or "on".

1. Turn the length adjustment knob 19 to the desired tape length.
2. Turn the knob for the cut piece spacing 51 to the Desired spacing.



## 刀片

刀片属于耗材。使用一段时间后，可能会变钝，需定期调整维护，或更换新刀片。

## THE BLADES

The blade are consumables, and they will eventually dull. When this happens you should replace the blades. how long the blades last will depend on the quality and thickness of the tape you're using.

## 取下上刀片

## HOW TO REMOVE THE UPPER BLADE

- 1、拧下4mm螺丝。
- 2、取下上刀片。



1. Remove the 4mm screw.
2. Take off the upper blade.

## 取下框臂

## HOW TO REMOVE THE ARM FRAME

- 1、取下弹簧。
- 2、使用手动摇杆使框臂自己上升。
- 3、拉出框臂。

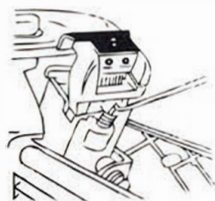

1. Remove the spring.
2. Raise the arm frame by using the manual lever.
3. Pull the arm frame out.

## 取下下刀片

## HOW TO REMOVE THE LOWER BLADE

- 1、拧下螺丝。
  - 2、拉出下刀片。
- 注：如果不能取出下刀片时，通过前后移动手动摇杆使下刀自己上升。

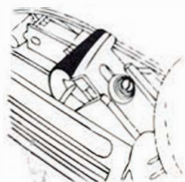

1. Remove the screw.
  2. Pull out the lower blade.
- Note: if you cannot take the Lower to lower blade off use the manual lever to cycle the cutter this will raise lower blade.

## 安装刀片

## PUTTING THE NEW BLADES ON

与“取下刀片”相所的操作步骤。

注：务必将下刀片和框臂牢固地装入。

Perform the blade removal steps in reverse.

Be sure to firmly insert the lower blade and arm frame.

## 调整上刀片

## HOW TO ADJUST THE UPPER BLADE

- 1、通过调节螺丝松紧调整上刀片。  
注：如果上刀片调整过大，刀片上下可能会碰撞上。
  - 2、装上胶带试着切割一下。
  - 3、一旦调节恰当拧紧螺丝，加以固定。
  - 4、再次切割胶带，如果能切割胶带，说明你调整的相当正确。
- 注：如果胶带切割的不是很漂亮，再稍微调整一下螺丝从而调整刀片。

1. Use the two adjustment screws behind the blade Ad just the upper blade inward by alternately tightening the two screws. Note: If you force the blade out, it might collide with the lower blade.
  2. Load the tape and try to cut it.
  3. Once the adjustments are correct tighten the top screw firmly.
  4. Try to cut the tape again. If the tape cuts, you have performed the adjustment correctly.
- Note: If the tape is not cut perfectly turn the adjustment screw a little at a time to further adjust the blade.

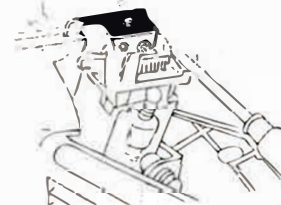

## 维护

## MAINTENANCE

如果机器使用一段时间后，胶带的胶水开始粘在刀片上，刀片就会变的很难切割胶带。为了把胶水擦掉，你可以用一块浸过汽油或酒精的布擦拭刀片。

如果胶带的旋转圆盘上粘不住，拿些胶带粘在圆盘上压紧，直到把污物粘掉。

If you have been using the 2-cut2 for a long time; glue from the tape starts sticking to the blades. And it becomes hard to cut. remove the glue with benzene or alcohol. If the tape won't stick to the carousel, press some tape sticky-side down onto the carousel this will remove any dirt on the carousel.

## 警告

## WARRANTY

以下情况，我们将对维修收费：

- 1、超过保修期(以保修卡的日期为准)。
- 2、保修卡丢失。
- 3、私自拆卸机器。
- 4、故意损坏机器。
- 5、取下胶带后，移动圆盘，机器仍可能启动。
- 6、使用完机器后，请将电源开关关闭，拔掉电源线。
- 7、搬动机器时，请勿抓住旋转圆盘，以免损坏机器。
- 8、机器只能用来切割胶带，切勿切割棍子、管子等硬物，以免损坏刀片。

It will be charged as follows:

1. Beyond the maintaining date (referring to the maintaining card)
2. Losing the maintaining card.
3. Knocking down without permission.
4. Destroy in purpose.
5. After getting down the adhesive tape, move the round plate but the machine is still able to start.
6. Turn off the power and pull out the power pack the before leaving.
7. Don't catch the round plate when you move it in case of destroy the loom.
8. The machine is only used to cut the adhesive tape and not in the truncheons, tubes etc that might damage the blade.

Part#	名称	Description	Part#	名称	Description
01	转盘	turn table	38	凸轮3	3-cam
02	按键组件	start switch	39	凸轮2	2-cam
03	拨动板	ratcher set	40	凸轮1	1-cam
05	凸筋片	slit plate	41	凸轮杆	cam shaft
06	转盘大压簧	spring	42	转动架	arm frame
07	自动开关控制	micro switch lever	43	刀头拉簧	spring
08	开关压簧	micro switch, spring(I)	44	刀架拉簧	spring
09	开关压簧	micro switch, spring(S)	45	底板	base
10	自攻螺丝PB3*16	screw	46	长曲柄	lever
11	上壳	body	47	曲柄+CU连接头	lever
12	开关	micro switch	48	保险座	fuse holder
13	标牌	nameplate(on turn table)	49	胶脚	rubber leg
14	透明罩	safety cover	50	凸轮支架	left chassis
15/16	左 / 右支架板	tape holder	51/54	转角调节组件	knob set, spacing
17	开关压片	switch cover	55	铝文架板	chassis, motor
18	微动开关	micro switch	56	拨动架	lever W/screw
19	长度调节组件	knob length adjustment	57	转盘拨杆拉簧	screw
20	标牌	nameplate, on body	58	单连齿轮	gear 1
21/24	下刀片组件	lower blade	59	双连齿轮	gear 2
25/26	上刀片组件	upper blade	60	双连齿轮	gear j
27Set	刀头组件	inward arm assembly	61	齿轮盖	gear cover/screw
27	刀头	inward arm	62	电机(120v)	motor 117V
28	刀头螺丝	spring/screw, blade adj	63	电机(220v)	motor 240V
29	压胶片	tape bite	64	小齿轮	pimon gear
30	刀头胶片	rubber stop	65	风叶	motor fan
31	刀头销孔	pin big	66	拨动片	tape set lever
32	刀头销	pin small	67	手调扭簧	coil spring
33	压胶板连杆	tape bite bar	68	棘爪组件	leVer
34	M6Lh螺母	nut, cam shaft	69	胶带盘	Tape drive
35	凸轮6	6-cam			
36	凸轮5	5-cam			
37	凸轮4	4-cam			

切割尺寸: 13-60mm

胶带宽度: 3-25mm

带盘尺寸: 内径-25、32、75mm

外径-量最大至130mm

(使用延伸装置, 最大外径可达170mm)

适用胶带: 乙烯基胶带 聚脂薄膜胶带

烯聚乙胶带 铁氟龙胶带

普通纸 玻璃布胶带

吕箔胶带 棉布胶带

双边胶带 等等!

可选: 延伸支架

电源要求: AC100V, 120V, 220-240V

50/60HZ 160W

体积: 300 (W) x 165 (H) x 170 (D) mm

重量: 2.85kgs

Cutting length From 13mm to 60mm(.5to2.360)

Tape width From 3mm to 25mm(.12to.980)

Core and Roll Size Internal Diameter D25,32,and 75mm(1,1.25, and 30) Outside Diameter D Up to 130mm(50) (When you use Extension Stand D) Maximum outside diameter is 170mm(6.70)

Recommended Tapes Vinyl Tape Cellophane Tape

Polyethylene Tape Masking tape

Teflon Tape Nomex Tape

Paper Tape Acetate Cloth Tape

Cotton Cloth Tape Glass Cloth Tape

Mylar Tape Aluminum foil tape

Double sided Tape Soft forming Tape

And More! Extension Stand

Optional Power Requirement AC 100V,120V,220-240V 50/60HZ 160W

Dimensions 300(W)x165(H)x170(D)mm

11.8(W)x6.5(H)x6.70(D)

Weight 2.85kgs.(6.4#)

## 零配件图

## PARTS

