



2-WA-D-EG-100

User Manual Of Gummed Tape Dispenser



Content

Disclaimer	III
1. Brief introduction	1
1.1 Product introduction	1
1.2 Basic parameters	1
2. Installation	2
2.1 Roll side plate installation	2
2.2 Brush assembly	3
2.3 Water bottle	4
2.4 Tape guide plate installation	5
2.5 Loading the tape	6
3. Detailed Operation	7
3.1 Start	7
3.2 How to use	8
4. Common malfunctions and solutions	13
5. Maintenance	15

PREFACE

Thank you for using the 2-WA-D-EG-100 Gummed Tape Dispenser. Please read this manual before you operate to ensure that you use the device correctly!

Disclaimer

The manufacturer and its authorized distributor are not liable for any accidents or damages resulting from the failure to comply with warnings or instructions depicted on this dispenser or contained in this operator manual, including:

- Improper use or maintenance
- Use for applications or under conditions other than those outlined in this operator manual
- Use of unauthorized parts
- Repairs or modifications made without the permission of the manufacturer
- Unauthorized alterations to the dispenser such as:
 - a) Alterations to the control system;
 - b) Welding, mechanical treatments etc;
 - c) Extensions to the dispenser or the control system;

The manufacturer and its authorized distributor are not liable for:

- Indirect damages caused by errors or malfunctions of the dispenser (e.g. damages to products, company interruptions, delays, etc.)

SAFETY

This dispenser has been designed for safe use in conformance with the application, conditions and rules described in this operator manual. Anyone that works with or on this dispenser must read the operator manual and follow the instructions carefully.

Operators

Only those who read and understand the Sections “Safety” and “Operator Instructions” should operate the dispenser. Special training is not required

Operator tasks include:

- Operating the dispenser ;
 - Regular maintenance (see section 5)
- Washing the tank ,brushes,and bottle.

Service technicians

Only service technicians employed by Get Packed Packaging or contractors are permitted to conduct service on the dispenser. For these individuals, a separate service manual is available.

Rules of Safety

- a. The power supply must be consistent with the parameters on the machine label, it is strictly prohibited for wrong connection, please only use the power cord provided with the product in order to prevent damage to the machine;
- b. Please ensure that the power supply is reliably grounded ;
- c. Pay attention to the occurrence of short circuits, breaks of the internal wiring of the safety switch during moving and carrying;
- d. Safety devices are not allowed to be switched off or removed ;

- e. Do not remove or cover warning labels ;
- f. Keep the working area clean and free of obstacles ;
- g. Unplug dispenser and gather all loose cords before moving the dispenser ;
- h. Pay attention when using hand tools such as knives, scissors etc, due to the risk of cutting ;
- i. Ensure that:
 - cords cannot be damaged ;
 - the working area is sufficiently lit ;
 - the working area is sufficiently ventilated.

Warnings

- a. Do not touch any rotating parts while the machine is working;
- b. Non-professionals are prohibited from opening the top cover and the right side cover for maintenance;
- c. It is strictly forbidden to touch the cutter when maintaining equipment;



- d. Do not touch high temperature cue area



- e. The machine is used in an environment above 0°C
- f. Press the emergency stop switch to cut off the total power supply of the machine with the following case:
 - There is jam in the inlet
 - Abnormal sound generated inside the machine
 - Other abnormal condition

Improper Use

The following applications or acts are not suitable for the dispenser, and constitute improper use of the dispenser:

- Use of materials other than those produced by Locked Paper and intended for use in the dispenser
- Use outside or in a humid area
- Use in areas subject to an explosion hazard
- Washing or cleaning the dispenser with excessive quantities of water
- Standing on the dispenser
- Placing objects against or on top of the dispenser
- Moving the dispenser while it is functioning or connected to the AC power supply.

1. Brief introduction

1.1 Product introduction

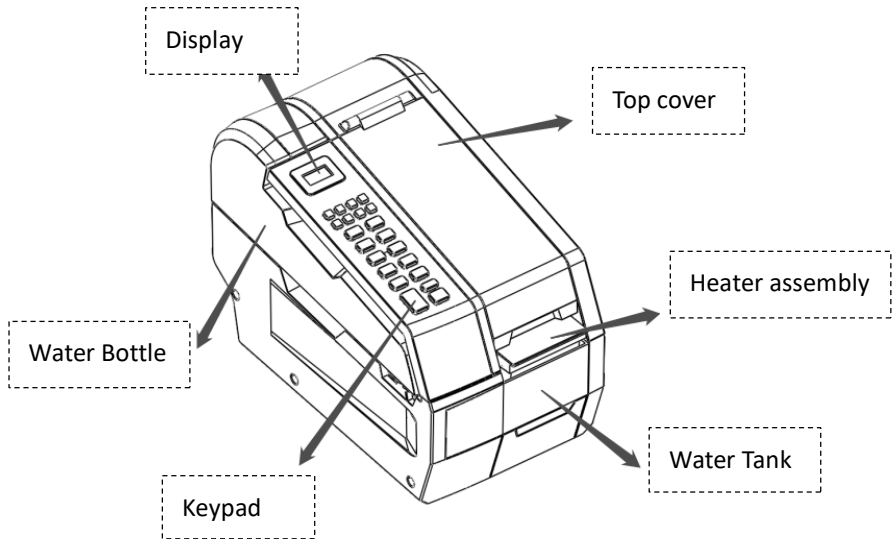

1.2 Basic parameters

Model	2-WA-D-EG-100
Power input	100/110/220V
Rated power	200W
Size	450x240x330mm (17.7x9.4x13inch)
Weight	12.5kg (27.5lb)
Cut paper length	13CM~300CM、5inch~120inch
Operating temperature	0°C~75°C、0°F~253°F
Contain	Machine hostX1 , Power cableX1 , User manualX1 , Wrench X3, FuseX1, Side plateX2, Short capX1

2. Installation

2.1 Roll side plate installation

- ① According to the tape width used, install the first roll side plate in the correct position;
- ② First insert the upper part of the side plate into the front slot;

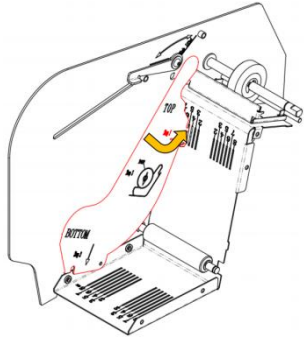

- ③ Finally, insert the bottom of the side plate into the bottom slot;

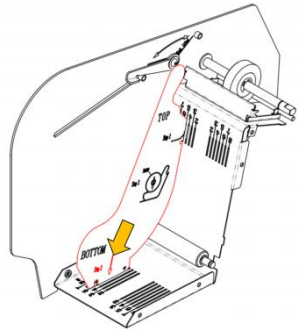

- ④ Repeat with the opposite roll side plate the tape roll should be central with some space either side, not too tight against the plates.

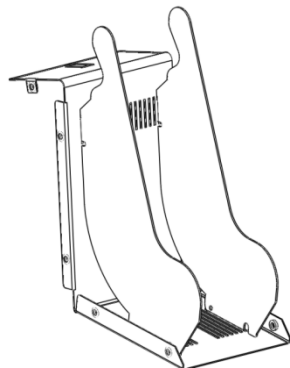

2.2 Brush assembly

- ① First take out the water bottle;
(Avoid water spills)

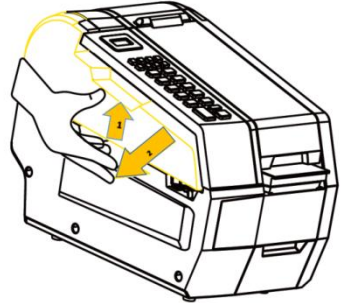

- ② Then take out the water tank with its brush.

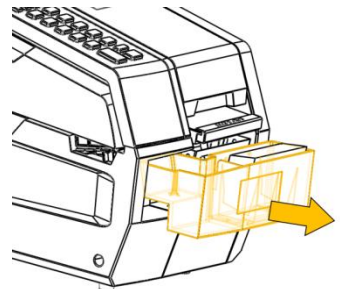

- ③ Water the top surface of the brush until the brush is completely soaked;
(Be sure to moisten the brush)

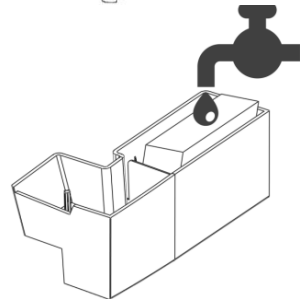

- ④ If replacing the brush, inserting the Brush into the water tank ,short side facing inward;
(see section 5)

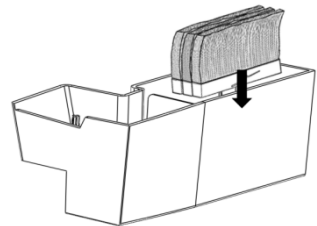

- ⑤ put the water trough in position, and then put back the water tank.

2.3 Water bottle

① Pulled out water bottle;

② Open the lid of the kettle, then fill the bottle with water

Caution: Do not drop the sealing ring of the lid of the water bottle

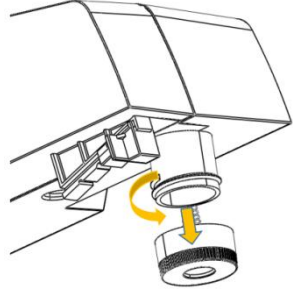

③ Tighten the lid of the kettle, turn over to see if there is a leak

④ Confirm that there are no water leaks, then, the water level in the water tank can be adjusted using the cam shown in Figure, Keep the brush moist---Normally, the water level is adjusted to the highest level.

Caution: Pay attention to the amount of water

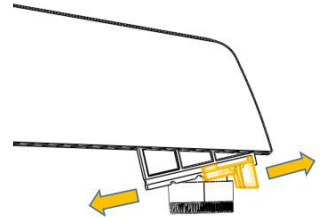

⑤ Place the water bottle on the machine.

Adjusting the amount of water applied to the tape:

Adjust the height of the water bottle:

- Higher to apply more water
- Lower to apply less water

• Never use any dispenser for water-activated tape without a water bottle.

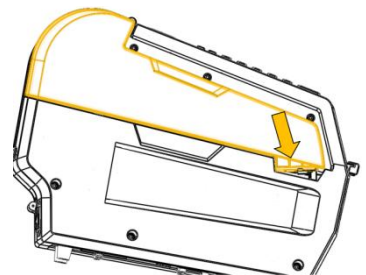

2.4 Tape guide plate installation

Check that the upper tape guide plate is the correct way up. Install the upper tape guide plate as shown below

The Upper tape plate must fit:

- Around the drive wheel
- Under the guide bar
- Over the rubber roller Drive Wheel

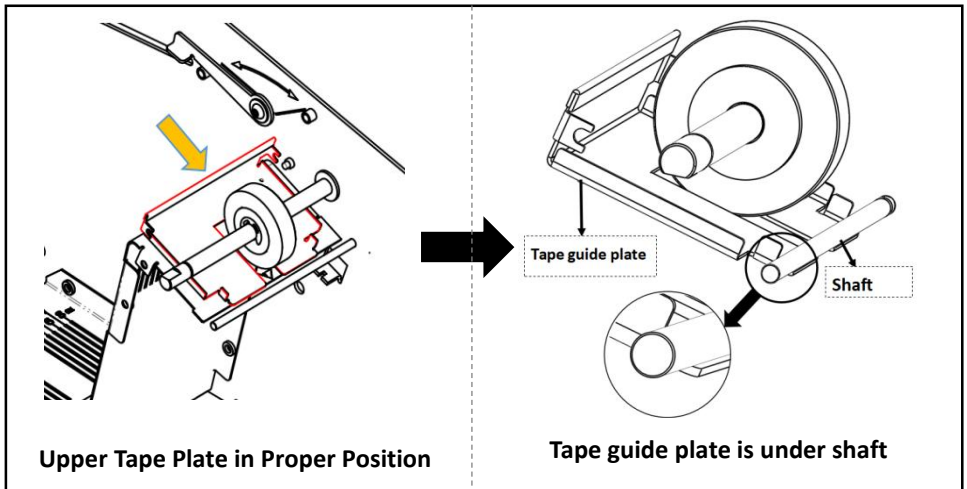
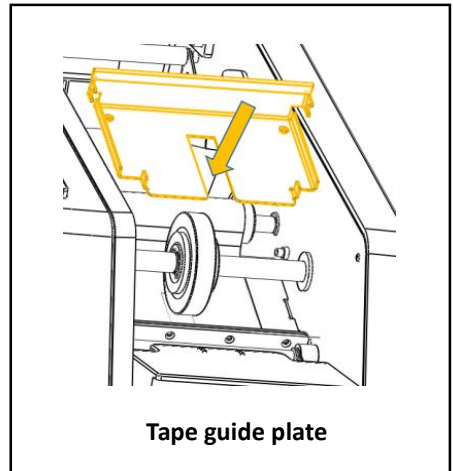

2.5 Loading the tape

Use scissors to cut the end of the tape so that it has a clean, square end to allow it to feed under the drive wheel. Remove the upper tape guide plate, while passing the tape under the drive wheel, pushing it forward until it meets the cutter blade. The unrolling direction depends on the pasting of the wet adhesive roller.

① In special cases, the pasting is on the inside, so that the adhesive tape roll must be unrolled from above.

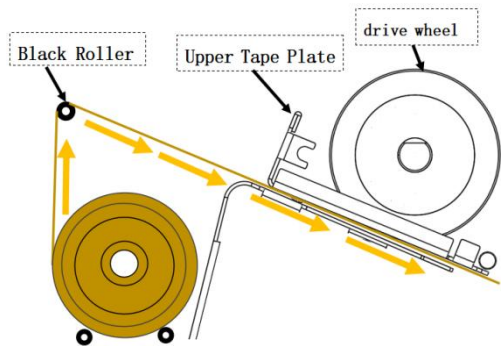

Inside pasting

② If the pasting is on the outside, the adhesive tape roll must be unrolled from below.

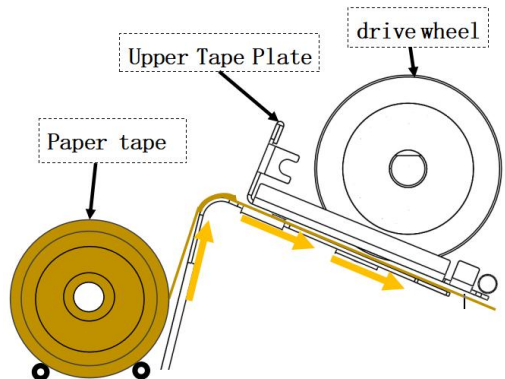

Outside pasting

Notice when feed the tape:

- Adhesive side down
- Around the lift roller
- Over the black roller
- Under the upper tape plate
- Under the guide bar
- Up against the shear blade.

3. Detailed Operation

3.1 Start

- ① Attach the power cord

Attach the female end of the power cord to the dispenser connector

- ② Turn the system 'ON'

Turn the power switch to the "ON" (up) position. The switch will light and the dispenser will "beep" once.

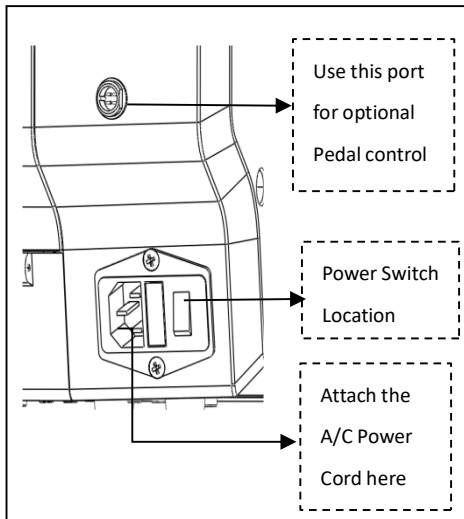

WARNING:

FOR YOURSAFETY

All metal parts of this machine are electrically grounded through a 3-wire power supply. You must plug this cord into a 3-wire grounded type receptacle.

3.2 How to use

Button Diagram (Centimeter Version)

Pressing a button or combination of buttons allows paper to dispense in length from 13cm to 300cm

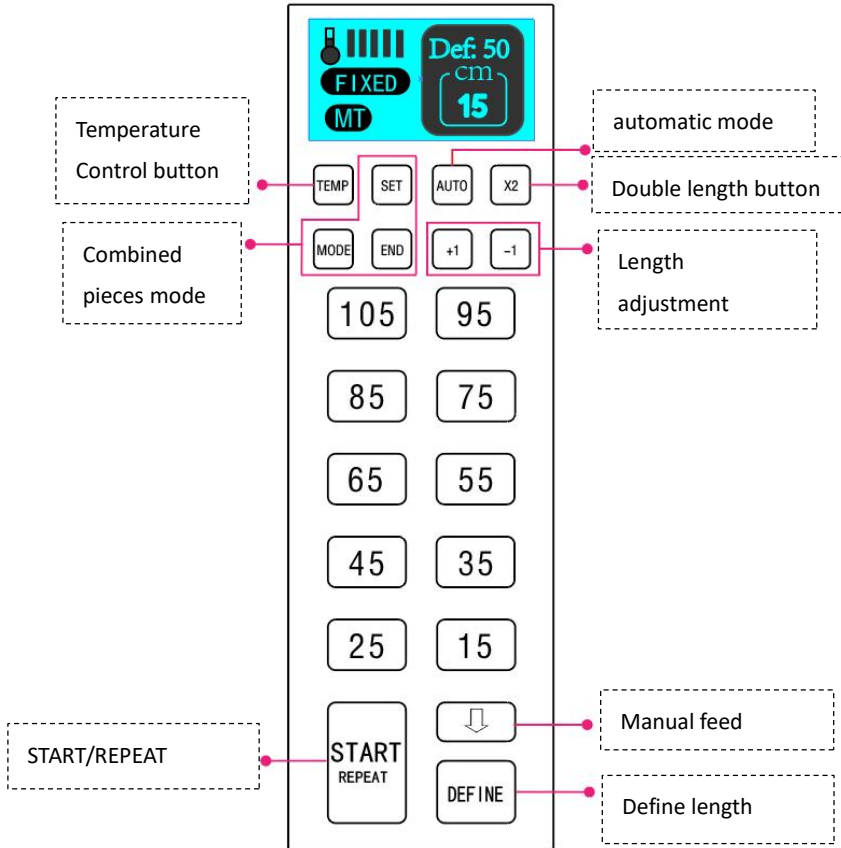

Button Diagram (Inch version)

Pressing a button or combination of buttons allows paper to dispense in length from 5inch to 120inch

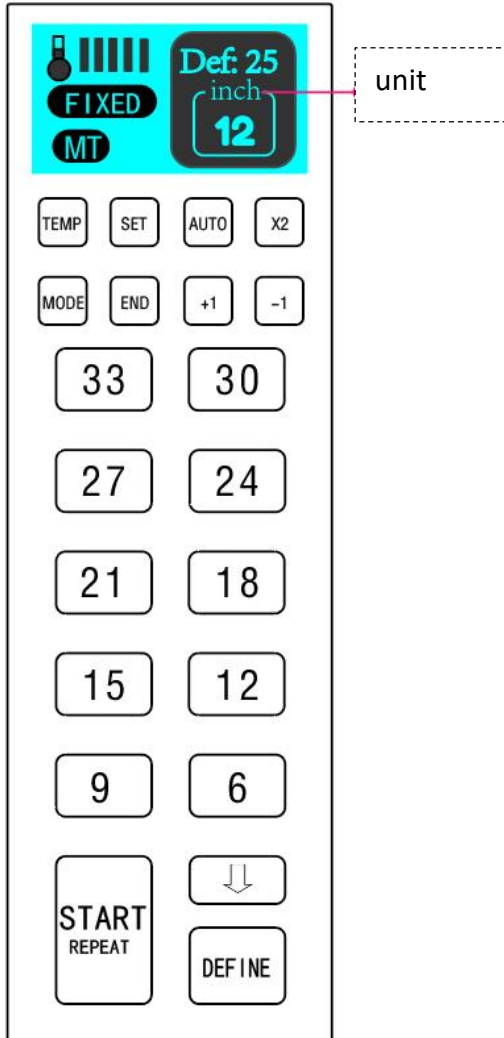

The following operating instructions take the centimeter version as an example

1) Temperature Control regulation

0: Not heated , 0-5: 5 different

temperature ranges: Summer setting: 1 , Winter setting: 5

- 1、 **TEMP** ascend in turn, 0 to 5: 
- 2、 Below 10°C, Use 5 gears;
- 3、 20-25°C, Use 3 gears
- 4、 37-40°C, Use 1-2 gears

When the heat is properly adjusted, the tape will adhere quickly to the parcel. Too low a setting may result in the tape taking slightly longer to properly adhere.

2) To dispense a length of tape equal to a number button length

Press To dispense 45

Press To dispense 95

3) To dispense a specific length not on a number button

-You can adjust a number button length (+1/-1) and then double it(X2).

To dispense tape longer than the amount on a number button :

For example: In order to dispense 17CM tape, press " +1 " button twice, then press the number button " 15 "

To dispense tape shorter than the amount on a number button :

For example: In order to dispense 24CM tape, press '-1' button once, then press the number button '25'

To dispense a length of tape twice the length of a number button :

For example: In order to dispense 30CM tape, first press ' X2 ' button, then press the number '15'

To adjust the length of a number button and then double it :

For example: In order to dispense 72CM tape, first press 'X2' button, press '+1' twice, then press the number '35'

4) TO repeat the length previously dispensed (REPEAT START Button)

The dispenser 'remembers' the last length of tape dispensed and stores that value in its memory.

Pressing the REPEAT key dispenses the same length of tape that was previously dispensed. This is especially handy if you are dispensing a tape length that was adjusted using the 'X2' or the '+1' buttons.

The REPEAT key also repeats standard number button lengths. Each time you dispense a different length of tape by pressing a different button or combination of buttons, that new figure:

- Is stored in the REPEAT button memory
- Becomes the length dispensed the next time you press the REPEAT button

5) To dispense a random length of tape

Press and hold the manual feed button () until the desired length of tape is dispensed.





It will dispense a length of 13cm to a maximum of 300 cm depending upon how long the button is held down.

- **Define length button**

For example: In order to make the machine to remember and dispense 115CM all the time, first press 'X2' → '+1' five times → '55', then long press 'DEFINE' button until the display shows 'Def: 115' → finished. Every time when you press 'DEFINE' button, it will dispense 115CM.



6) In order to dispense different sizes (Combined pieces mode)

For example: 15-35-55-115CM continuously,

First, press  to change to **COMB** mode; Second, press  → '15' → '35' → '55' → 'X2' → '+1' five times → '55' → , Third, press , machine will dispense 15CM, 35CM, 55CM then 115CM. Press  again to return back from **COMB** to **FIXED** mode.

(*will indicate current number in group if comb mode is on)

- **Automatic mode**

Press  then press any number, machine will out feed one same piece with preset length once the former one is taken away. Press  again to cancel the automatic mode. This model could be used together with **COMB** or **FIXED** mode.

4. Common malfunctions and solutions

Code	Detail	Operation
E01	There is paper at exit	Check if paper jam inside and clean
E02	No paper at exit	Check if no material or the paper is being rolled back under the AOOUT → AT mode.
E03	Motor is abnormal	Proceed as follows
E04	Cover open/The magnet signal is lost	Close the cover and check the location of magnet

- **E03 alarm solution:**

(1) Check whether the rubber wheel rotates abnormally, please refer to step ③ if it rotates normally;

(2) The motor is abnormal if the rubber wheel does not rotate and this part needs to be replaced, please contact the after-sales service in time;

(3) It is an abnormal grating sensor and needs to replace if the rubber wheel rotates normally, please contact the after-sales service in time;

(If the rubber wheel rotates normally and needs to continue to work, you can switch to timer mode if you are not able to replace the parts : in MT mode, long press SET to enter the password interface, enter the password (Metric

version 95 55 25 75 、 Inch version 30 18 9 24), press END to enter the engineering interface, press SET and select the TIMER mode, short press END to return to the home page, but the length of the paper in this mode will have a ±5cm/ ±13inch tolerance; And the use of TIMER mode will have certain risks, please replace the parts in time)

- **Clearing jams**

If the tape jams inside the dispenser near the cutting blade, proceed as follows

- (1) Turn the dispenser OFF and UNPLUG it.
- (2) Remove the tape guide plate

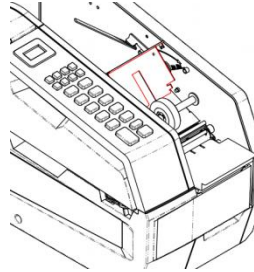

- (3) Lift the shear blade by manual handle

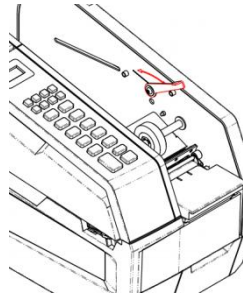

- (4) Remove the remaining tapes under tape guide plate

- (5) Lift the heating cover and remove the remaining tape

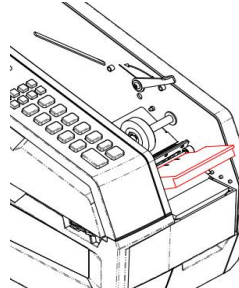

- (6) Restore position of the tape guide plate, manual handle and heating cover.

- **Changing the fuse**

If the dispenser is plugged in but doesn't work, it is probably the safety interlock switch. The safety interlock switch makes contact when the top cover is properly closed. Before performing any other diagnostic checks, ensure that the top cover is fully closed and that the switch is activated when the cover is closed. If the top cover is properly closed and the on/off switch doesn't light in the "ON" position, it may indicate a blown fuse.

Proceed as follows:

- (1) Turn the dispenser OFF and UNPLUG it
- (2) Take out the fuse placement slot in the middle of the power switch (Pry it open)
- (3) Replace the fuse. Preference is given to the fuse of the accessory kit, If the fuse runs out, Please contact the after-sales service, or buy the right fuse (Different models may cause damage to the machine) .

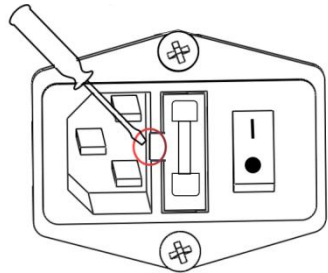

5. Maintenance

There is very little maintenance required to keep your tape dispenser working in top condition. However, the maintenance that is required is important to perform.

Maintenance is basically:

1) Cleaning the water tank, bottle, and brushes

Brushes: Glue from the tape may accumulate and reduce the effectiveness of the moistening system. Wash brushes weekly with mild soap.

WARNING:

Never cut the ends of the brush tips to remove dried glue ... the brush will be too short and will not work properly.

Caution :

Installed brush is parallel to the water pot and positioned towards
The front edge of the water pot.

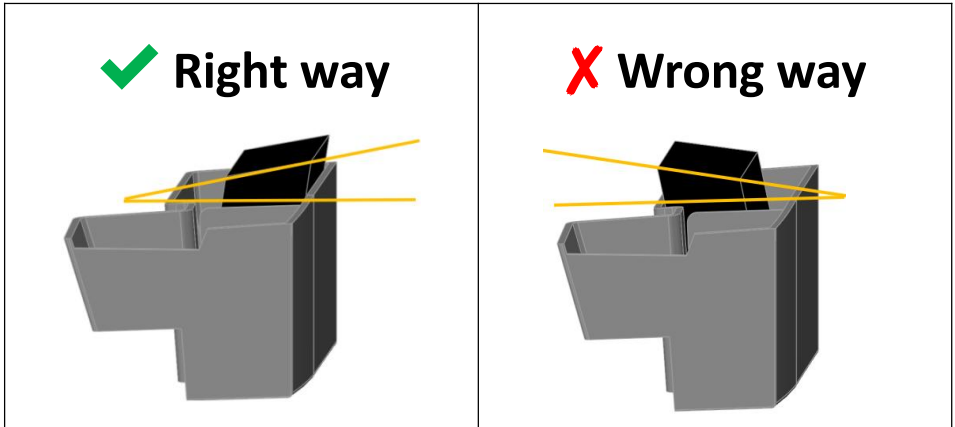

2) Keeping the shear blade clean

For the dispenser to cut the tape well, blades need to be free of adhesive, dust etc.
These materials need to be cleaned from the blade.

WARNING:

Be sure the dispenser is OFF before performing any cleaning operations.

Suggested preventative maintenance schedule:

Weekly

- Wash water brushed with mild soap; rinse well.
- Clean any accumulated tape dust with a dry brush or blower.
- Wash water tank with mild soap; rinse well.

Monthly

- Clean accumulated glue from blades using a scraper.
(Don't scrape the cutting edge, the blade may dull and need replacement).
- Caution: The blade is sharp and can cut easily, be careful working around it.
- Apply light coating of light machine oil to back of blade.

Annually

- Thoroughly clean all accumulated pieces of tape, tape dust and any other foreign material from inside the machine with dry brush or blower.
- Clean bottom of heaters and pressure plates of accumulated glue.
- Oil upper and lower blades lightly with light machine oil.
- Clean all covers with damp rag.